



North American Society for Trenchless Technology
2008 No-Dig Conference & Exhibition



Dallas, Texas
April 27 – May 2, 2008

NEW DEVELOPMENTS IN LINER DESIGN DUE TO ATV-M 127-2

Bernhard Falter¹

¹ Dept. of Civil Engineering, University of Applied Sciences Münster, Germany

ABSTRACT: The German Code ATV-M 127-2 published in 2000 for the design of linings to rehabilitate sewers has proved itself a helpful guideline to find the optimum wall thickness of any liner material, e.g. CIPP or stainless steel manchettes. Many rehabilitation projects in different European countries have been performed successfully using this code.

The code differentiates between three host pipe states: State I for untight sewers without cracks, state II for sewers with longitudinal cracks but a stable soil pipe system and state III for cracked pipes with larger deformations and considerable risk to collapse in the near future. State II sewers but installed close to the traffic surface must be calculated as a state III situation too. According to the code stress, deformation and stability tests are necessary. For many practical cases charts with stress factors and imperfection reductions allow to design without a computer.

Numerous theoretical and experimental papers are available which mainly deal with circular linings. An evaluation of design codes carried out by experts of different countries shows a fairly good coincidence of the required wall thicknesses, but the assessment of pipeline damages by engineers is sometimes resulting in quite different assumptions necessary for the design input parameters.

The paper reports about the progress in liner design since the 1st edition of the code. Additional clauses have to be introduced into the 2nd edition for non circular geometries (e.g. for hood and rectangular profile), imperfections describing practical and theoretical situations and new applications (e.g. railway crossings). International discussion can be useful to find safe and resources saving constructions.

1. INTRODUCTION

The critical water pressure equation is based on a Glock formula (Glock, 1977) for elastic rings encased in a rigid boundary. This equation was used by many researchers and enhanced by reduction factors to describe the real situation of the host pipe (e.g. deformations and annular gap). In a few codes the critical pressure of an unsupported ring (Timoshenko, 1961) is used and increased by a support factor K ; for example $K = 7$ for good and 4 for poor installation conditions (WRc/WAA, 2000).

The critical soil pressure is treated less often in research papers. The reason might be that experiments on the broken pipe soil-system with an overburden (e.g. Watkins, 1988) show a conservative behaviour without a collapse. On the other hand in such experiments uniformly distributed pressures are applied onto the sandbox surface more often than concentrated wheel forces.

2. DESIGN CONCEPT OF THE CODE M 127-2:2000, 1ST EDITION

2.1 HOST PIPE STATES

The German liner design concept is based on the differentiation of three host pipe states. The state I and II (without and with longitudinal cracks) must be calculated only for groundwater acting as a pressure on the outside of the lining. In case of state III an additional calculation for soil and traffic loads is prescribed.

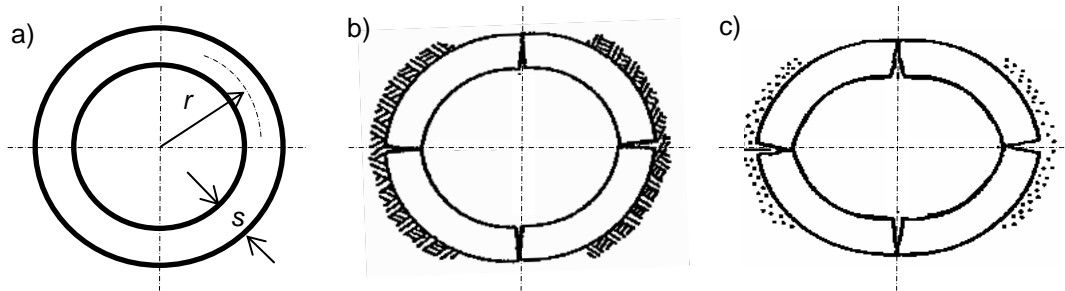

Figure 1a-c. Host pipe state I (a), II (b) and III (c) as defined in the German Design Code ATV-M 127-2

2.2 BUCKLING PRESSURE, IMPERFECTION REDUCTIONS AND PROOF OF STABILITY

Due to the Code ATV-M 127-2 the buckling load for the water pressure p_a valid for all host pipe states is evaluated regarding three kinds of imperfections, cf. Figure 2:

- Local imperfection $w_v = 2\%$ which must be chosen according to the relevant buckling mode
- Annular gap $w_s = 0.5\%$ for CIPP caused by shrinkage of the liner material
- Global imperfection $w_{GR,v} \geq 3\%$ caused by the deformation of the cracked host pipe

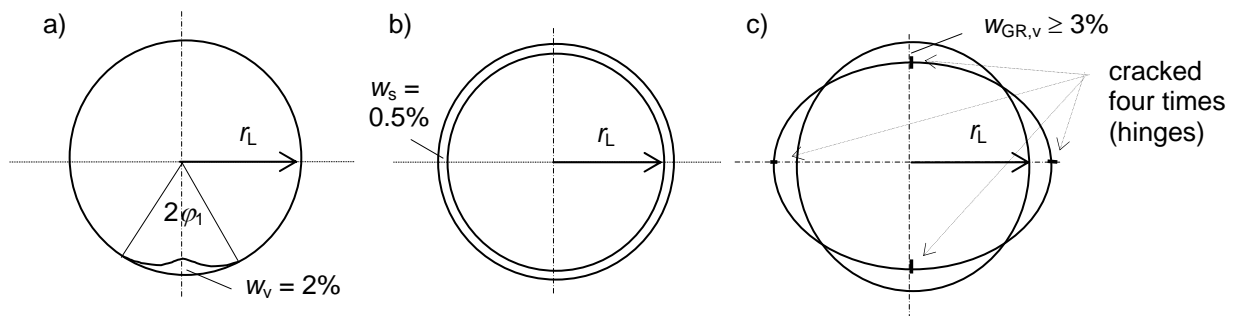

Figure 2a-c. Local imperfection w_v (a), annular gap w_s (b), global imperfection $w_{GR,v}$ (c), minimum values

For the imperfections in Figures 2a-c reductions factors κ for the buckling load are given in the Design Code. The factors depend on the depth of the imperfection and the r_L/s_L ratio describing the slenderness of the liner construction and the character and the size of the host pipe damages.

For the critical water pressure p_a of a circular lining the following formula yields (Falter, 1993):

$$\text{crit } p_a = \kappa_{v,s} \cdot \alpha_D \cdot S_L \quad [1]$$

where $\kappa_{v,s} \cong \kappa_v \cdot \kappa_s \cdot \kappa_{GR,v}$ is the common reduction factor for all imperfections due to Figures 3a-c
 $\alpha_D = 2.62 \cdot (r_L / s_L)^{0.8}$ is the snap through factor (Glock, 1977) and
 $S_L = E_L / 12 \cdot (s_L / r_L)^3$ is the ring stiffness of the liner (E_L = long-term Young modulus)

The minimum values for w_v , w_s and $w_{GR,v}$ to be applied are given in Figures 2a-c and 3a-c. The main problem in the practice is the correct assumption of the global imperfection $w_{GR,v}$. Usually this value has to be evaluated from a video screen which results in sometimes different opinions of the engineers about this issue.

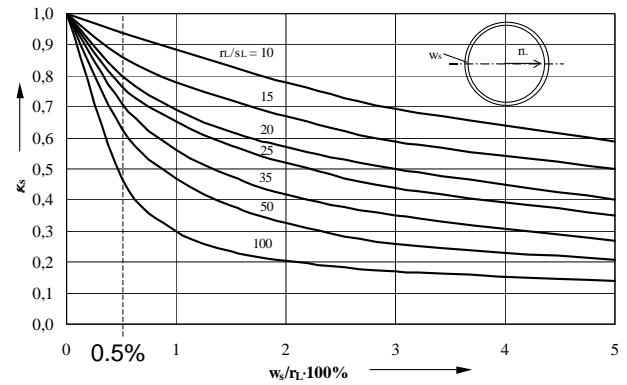
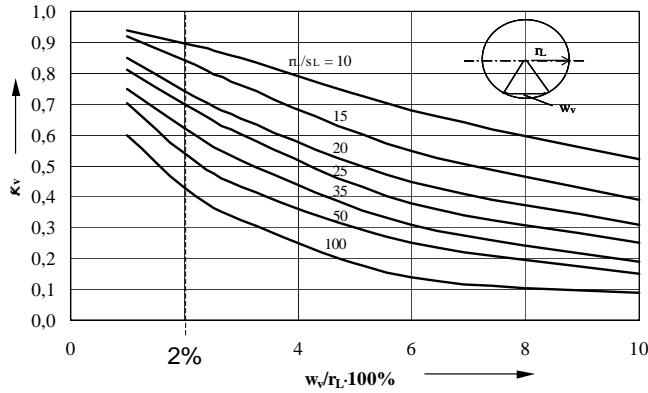
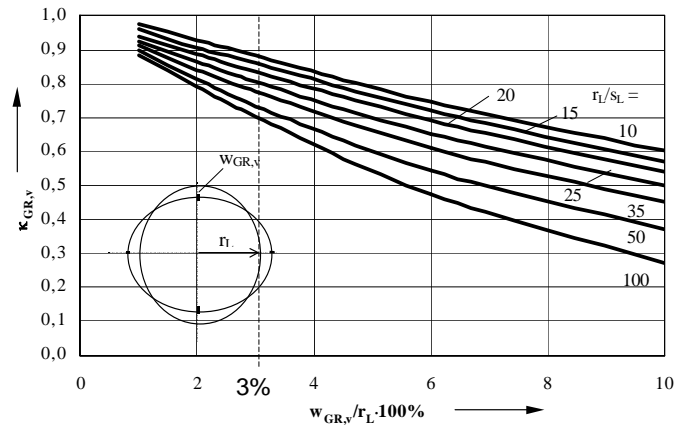

Figure 3a-c.
Reduction factors κ_v , κ_s and $\kappa_{GR,v}$ for the buckling pressure due to local imperfection w_v , annular gap w_s and global imperfection $w_{GR,v}$;
source: ATV-M 127-2:2000

For non circular linings a computer evaluation of the critical water pressure is necessary or a substitute radius on the safe side has to be taken for r_L in Eq. 1.



2.3 PROOF OF STRESSES / STRAINS

The section forces M and N caused by groundwater pressure p_a are calculated by means of dimensionless factors m_{pa} and n_{pa} given in appendix A4 of M 127-2 for the diameters ND 200 - 600, cf. Figure 4.

$$M_{pa} = m_{pa} \cdot p_a \cdot r_L^2 \quad \text{with } m_{pa} \text{ due to appendix A4 in Code M 127-2} \quad [2a]$$

$$N_{pa} = n_{pa} \cdot p_a \cdot r_L \quad \text{with } n_{pa} \approx -0.8 \text{ bis } -1.1 \quad [2b]$$

The stresses are calculated using Equations 3a, b:

$$\sigma_j = \frac{N}{A} + \alpha_{ki} \cdot \frac{M}{W} \quad \text{with } \alpha_{ki} = 1 + s_L / 3r_L, \alpha_{ka} = 1 - s_L / 3r_L \quad [3a]$$

$$\sigma_a = \frac{N}{A} - \alpha_{ka} \cdot \frac{M}{W} \quad A = s_L \text{ in mm}^2/\text{mm} \text{ and } W = s_L^2 / 6 \text{ in mm}^3/\text{mm} \quad [3b]$$

The resulting tensile stress is compared with the ultimate flexural strength of the lining material, reduced for long-term behaviour. As the pressure stresses due to Eq. 3b are a bit larger an additional material pressure test leads in many cases to a more economical design.

For host pipe state III the soil and the traffic loads q_v are applied to the pipe's crown and the structural safety of the total system of soil, cracked host pipe and lining is analysed. The axial force and bending moment factors n_q and m_q are given for ND 200 to ND 600 in appendix A5 of Code ATV-M 127-2.

Elaborate experiments have been necessary to prove the design formula, referring to national and international research, cf. chapter 4.3.

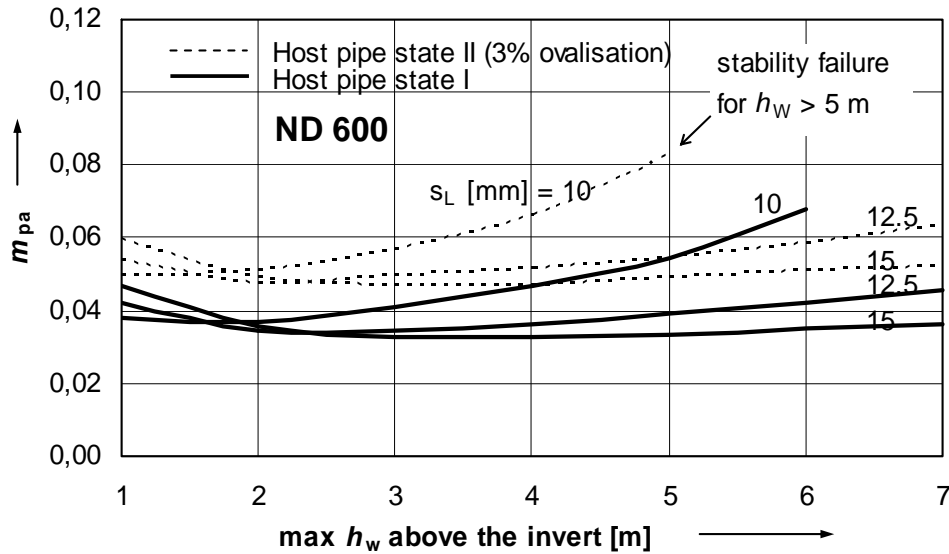

Figure 4. Invert bending moment factors for a lining with ND 600, source: Appendix A4 in M 127-2

2.4 DISCUSSION

The *stress proof* in chapter 2.3 is the most important test. The factors m_{pa} calculated non linearly with appropriate imperfections contain the risk of stability failure. In many cases computer analysis is necessary as the validity of the cross section factors is restricted to a range of material properties. The *stability proof* in chapter 2.2 has the advantage of general validity for all diameters and all material properties. This proof can be used for approximate evaluations of the wall thickness without computer programs. *Deformation analyses* are less important and used sometimes for judgement of serviceability.

3. EXTENSIONS OF THE DESIGN CODE M 127-2, 2ND EDITION

3.1 ADDITIONAL REDUCTION FACTORS FOR THE BUCKLING LOAD

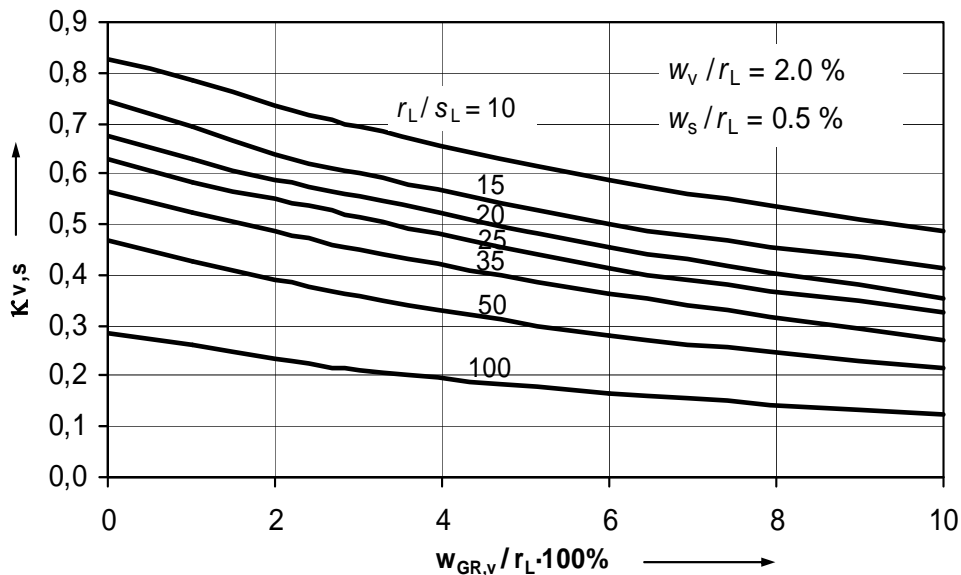

Figure 5. Reduction factors $\kappa_{v,s}$ of the buckling pressure, 2% local imperfection, 0.5 % annular gap and arbitrary global imperfection (Falter, 2003)

The regular values for most rehabilitation situations with CIPP-liners are 2% local imperfection, 0.5% annular gap and an arbitrary global imperfection. For this constellation only one chart with reduction factors $\kappa_{v,s}$ for the critical pressure is necessary, cf. Figure 5.

3.2 SIMULTANEOUS CALCULATION OF WATER AND SOIL PRESSURE

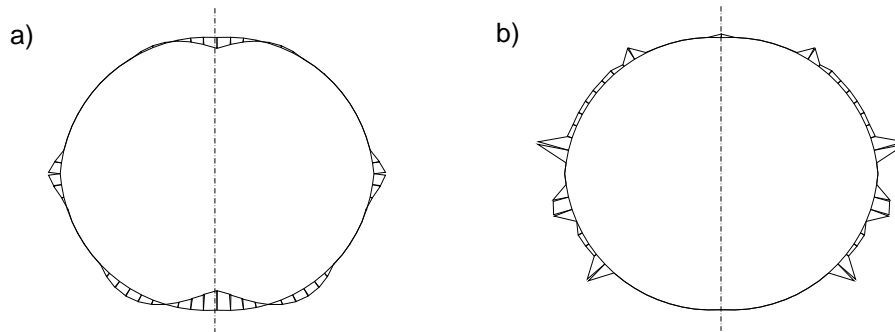

Figure 6a, b. Load cases groundwater p_a and soil pressure q_v – a system without horizontal symmetry, a) bending moments of the liner, b) contact forces liner versus host pipe (Linerb, 2007)

In the Design Code ATV-M 127-2:2000 the load cases p_a and q_v are treated separately. Subsequently they must be combined by an interaction formula. New developments show that an enhanced numerical model is able to cover both load cases in one step. For host pipe state III without water table a double symmetry of the system could be assumed; in the case of a load combination this is however no longer possible, cf. Figure 6a,b.

3.3 LINING OF FLEXIBLE SEWERS

Obviously rehabilitation projects of damaged flexible sewers are increasing. The dominant damage cases are deformations exceeding the value of 9% of the nominal diameter allowed due to German codes. The assumption of a rigid liner encasement has to be abandoned in these cases.

3.4 SOIL BEDDED LININGS (HOST PIPE FULLY DETERIORATED)

Sometimes the future integrity of the old pipe is called into question. In the Design Code ATV-M 127-2 it is assumed that the host pipe has enough strength to support the lining in the radial direction. If the absence of any host pipe structure is expected in the future new analysis problems arise: The liner without host pipe. The main stresses are now to be expected in the liner crown, cf. Figure 7a.

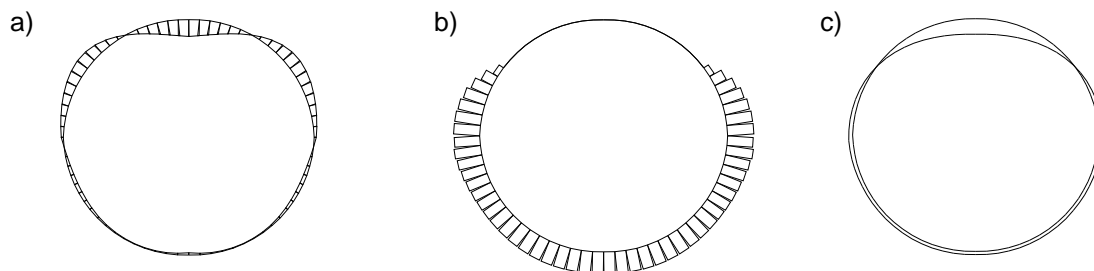

Figure 7a-c. Bending moments (a), contact forces (b) and deflections (c) of a circular lining subjected to groundwater - host pipe neglected (Linerb, 2007)

3.5 HOST PIPE SOIL-SYSTEM

In order to prove the host pipe soil-system the equilibrium of a rigid circular ring with four excentric hinges is investigated, cf. Figure 8. For regular cases with elastic soil behaviour the load deflection curve is described by the following equation:

$$\frac{q_v}{S_{Bh}} = \frac{\xi \cdot \eta_S \cdot (\rho_{Gy} - \eta_S / 3 - \eta)}{(1 + \xi) \cdot (2\rho_{Gx} - 1 + \xi) - K_2 \cdot (1 - \eta) \cdot (2\rho_{Gy} - 1 - \eta)} \quad [4]$$

where ρ_{Gx} and ρ_{Gy} = horizontal and vertical distance of the excentric hinges from the pipe center
 η = deflection of the pipe's crown to the inside, ξ = outside deflection of the springline
 η_S = vertical extension of the side bedding (all parameters related to the pipes radius) and
 K_2 = factor of lateral soil pressure.

Eq. 4 yields the dimensionsless ratio of the crown loading q_v and the horizontal bedding stiffness S_{Bh} of the soil. The equation has been extended for initial deformations and plastic soil behaviour. The resulting load deflection curves show maximum values $crit\ q_v$ which are valid for cracked pipes surrounded by soil. In appendix A6 of the Design Code ATV-M 127-2 Eq. 1 has been evaluated for varying soil groups and hinge excentricities, cf. Figure 9.

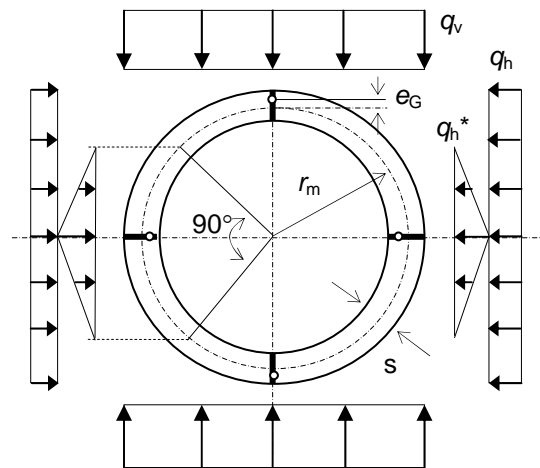

Figure 8. Pipe with longitudinal cracks and soil pressures q_v , q_h and q_h^* (support)

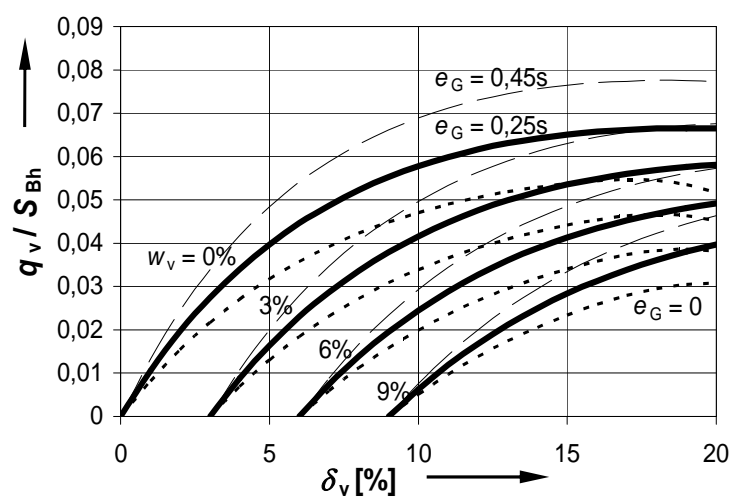

Figure 9. Load deflection-curves of the pipe soil-system for soil group 1, varying imperfections + hinge excentricities e_G

4. THEORETICAL BACKGROUND AND EXPERIMENTAL EVALUATION

4.1 NUMERICAL MODELS USED FOR LINER DESIGN

Table 1. Numerical models in liner design

Model	Application	Advantages	Disadvantages	Example
1. Beam model	Basis of the diagrams in Code M 127-2:2000, familiar in practice	Inexpensive, quick dimensioning, possible for all profiles	Lining material regularly linear	Chapters 5.2 - 5.4
2. Two dimensional	Special profiles	Non linear behaviour of soil and lining material	Relatively complex	-
3. Three dimensional	Special investigations, no constant situation in longitudinal direction	Research, spatial load distribution, anchored linings etc.	Complex and expensive	Chapter 5.1

Several models used in practice and research studies are shown in Table 1. The most usual one is the beam structure, cf. Figure 10a.

4.2 NUMERICAL MODEL AS A BASIS OF THE DESIGN CODE ATV-M 127-2:2000

The computer model is a structure of connected arcs described by beam elements and rigidly supported by the host pipe, cf. Figure 10a. All necessary imperfections are introduced in the model and can be chosen arbitrary. The calculation is performed non linearly in order to evaluate stress *and* stability limits as well.

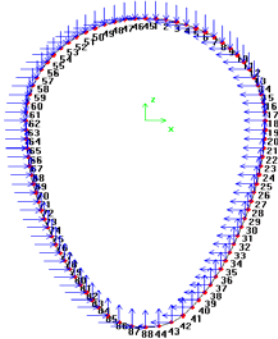

Figure 10a. Beam model for egg-shaped liners, loading

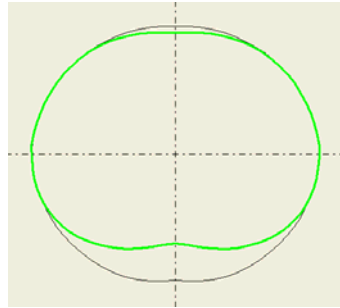

Figure 10b. Admissible deflection with one lobe in the invert

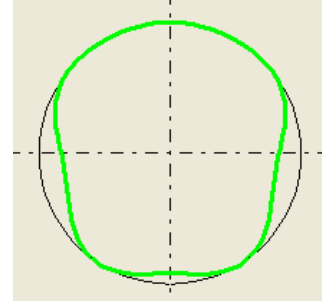

Figure 10c. Not acceptable multi-lobe figure for host pipe state I

Figure 10b shows an appropriate solution for host pipe state II with a single lobe deflection. The deflections in Figure 10c have been calculated assuming a water pressure exceeding the buckling load. The beam model for an egg shaped liner in Figure 10a includes a local imperfection at the right side beneath the springline.

4.3 EXPERIMENTAL EVALUATION

From numerous experimental research on lining stability two buckling test series are shown in the Figures 11 and 12. The correct way to perform such buckling tests regarding the material's creep tendency is to estimate the time until buckling and to apply the pressure at the outside as a load *constant with time*.

The results are in good agreement with the calculated critical pressures, using the buckling Equation 1 or the numerical model described in chapter 4.2.

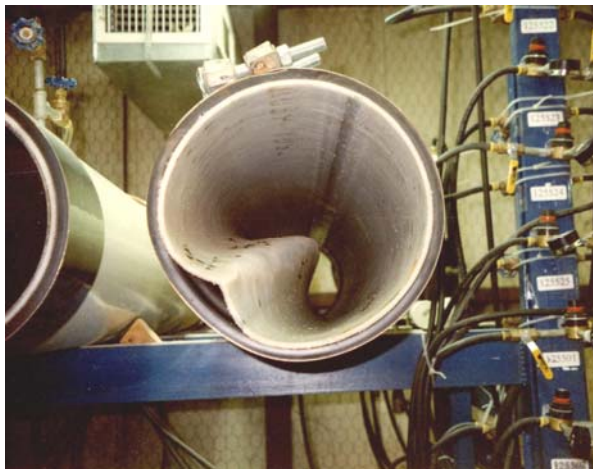

Figure 11. Long-term buckling tests on CIPP linings of the Louisiana Tech University (Guice et. al. 1994)

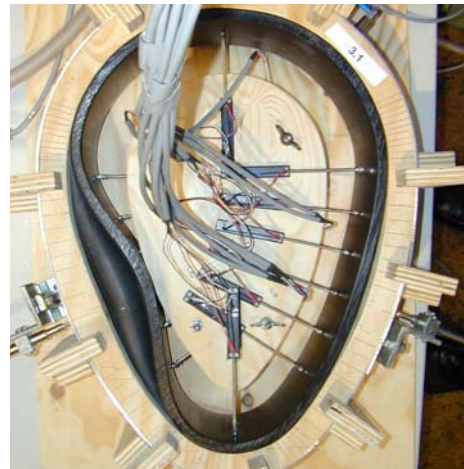

Figure 12. Creep buckling tests on egg-shaped PE linings, University of Applied Sciences Münster (Falter, 2008)

5. CASE STUDIES

5.1 HAFENKANAL IN DÜSSELDORF (2004)

The Hafenkanal sewer ND 2500 mm in Düsseldorf, Germany made of reinforced concrete was heavily damaged by sulphuric corrosion. Nevertheless it could be classified as a host pipe state I sewer.

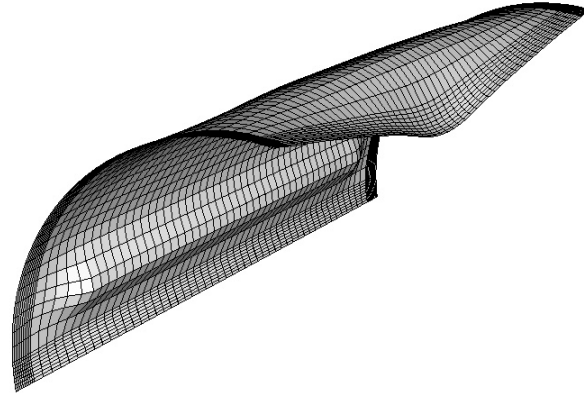
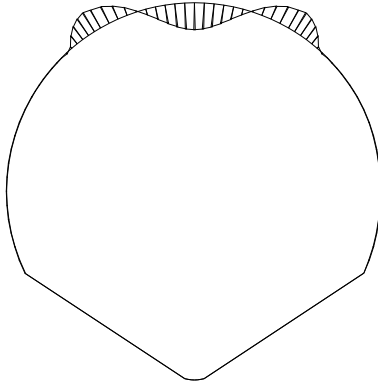

Figure 13. Beam model, bending moment

Figure 14. 3D simulation, imperfection, deformations

One proposal for the renovation was to cover the sewer's surface by anchored 8 mm thick polyethylene sheets with backside burls. Thus the sheets are drained by an annular gap and notches at both springlines. The distance of the bolts was originally planned as 0.5 m in axial direction but could be increased to 4 m by the calculations, cf. Figures 13-14. Beam and three-dimensional models were examined. The three-dimensional model was necessary to analyse the shell bearing behaviour. The dead load of the liner and temperature changes of ± 7.5 K were applied; a maximum crown deformation of 15 mm for all load combinations was allowed by the client.

The installation of the sheets and the finished work are shown in the Figures 15 and 16.



Figure 15. Erection device to press the 4 m long polyethylene sheets against the culvert



Figure 16. Sewer in Düsseldorf, Germany after renovation (Photos: H.I. Hammer)

5.2 SEPARATION OF THE MÜNZBACH RIVER FROM WASTE WATER IN FREIBERG (2005)

In the hood-shaped concrete sewer in Freiberg, Saxonia in Germany, the water of a small river was transported simultaneously. Thus the aim was to separate the streams within an assembled lining and to improve the load-bearing capacity of the sewer. During the analysis of the sewer and the lining for host pipe states II and III some special problems occurred:

1. Analysis of the existing sewer's stability suffering from side cracks and infiltration.
2. Optimization of the sewer's shape to avoid excessive arching forces from the flat invert caused by groundwater pressure, cf. Figures 17a, b.
3. Application of safe imperfections to the flat part of the cross section, cf. Figures 18a, b. In the present case a non symmetrical pre-buckle must be applied.
4. Quality control of the liner material and the bonding connections of the segments, cf. Figure 19.

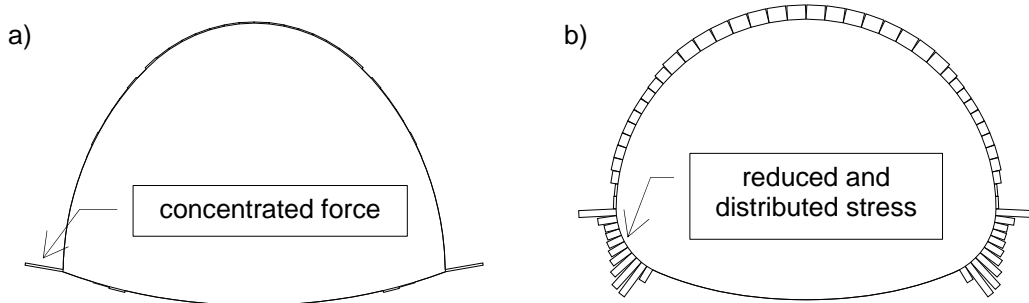

Figure 17a, b. Contact forces between polycrystalline liner and grout, a) sharp edges and b) rounded edges

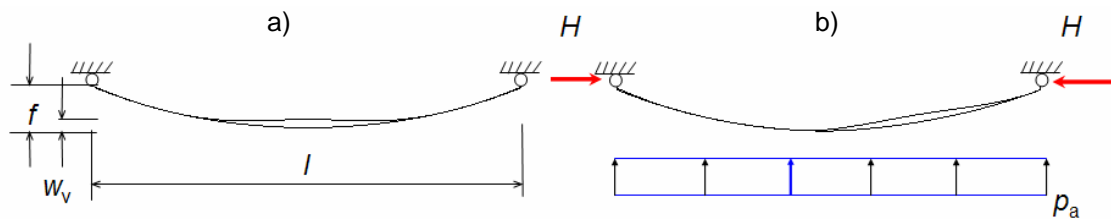

Figure 18a, b. Model of the invert shallow arch subjected to water pressure p_a , a) symmetric and b) non symmetric imperfection

For the project dimensions $l = 2.75$ m and $f = 0.25$ m the following horizontal forces H caused by a water table of 1.5 m above the invert ($p_a = 15$ kN/m²) result:

$$H = p_a \cdot l^2 / 8f = 15 \cdot 2.75^2 / (8 \cdot 0.25) = 56.7 \text{ kN/m.}$$

As a consequence of the high forces H the liner shape must be a carefully chosen in this region and the edges should be rounded. Figures 19 and 20 show a bottom element with sharp edges as designed in the first construction phase and the installation. For the second phase elements of the whole cross section with rounded edges were manufactured, cf. Figure 17b.



Figure 19. Polymeric concrete invert element



Figure 20. Assembly of the liner elements, bonding

5.3 MASONRY SEWER CROSSING A RAILWAY IN KREFELD (2007)

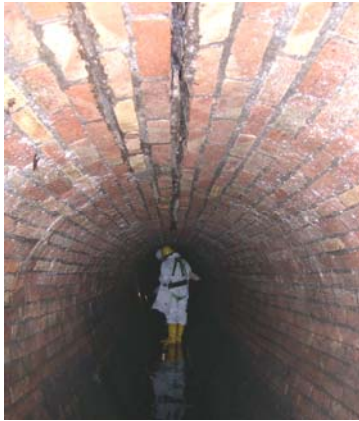

Figure 21. Sewer with longitudinal cracks

Figure 22. Installation of the CIPP lining

As the egg shaped sewer $B/H = 1200/1800$ mm sewer crossed a railway in Krefeld, Germany it was necessary to rehabilitate the full length of 350 m between the two manholes in one step. Thus the required wall thickness was a question if the rehabilitation could be done at all. The main design issue for this project was the crown deflection. The first approach for the crown deformation was 3%, but an inspection with different measurements (height, width, crown gap width and angle difference in the crown, cf. Fig. 21) yielded 5% deformation except a part of 15 m length with 10%. Thus two liner wall thicknesses were manufactured: 23 mm regularly and 30 mm in the largely deformed area. It was possible to restrict the whole weight of the wet lining to 180 tons, the ultimate weight for a street transportation, cf. Figure 22.

5.4 RAILWAY CROSSING BANBURY STATION SEWER, UK (2007)

The Banbury Station Sewer had a brick walled cross section changing over the length: rectangular, inverted horse shoe, circular ND 800. Therefore and regarding the severe damages of the sewer a slip lining procedure was chosen with a grouted annular space.

A part of the sewer had to be exchanged by a new GRP pipeline and open cut. Regarding the shallow cover above the sewer of only 0.69 m the main problem in design was the requirement of the railway authorities to ensure that the settlements under the sleepers should not exceed 3 mm. Due to the British Standards newly laid pipes should have a minimum cover of 1.5 m. Because of the vicinity to the wheel loads a fatigue analysis for the pipeline material was necessary. Many liner materials have not been tested under cyclic loading yet.

6. INTERNATIONAL COMPARISON

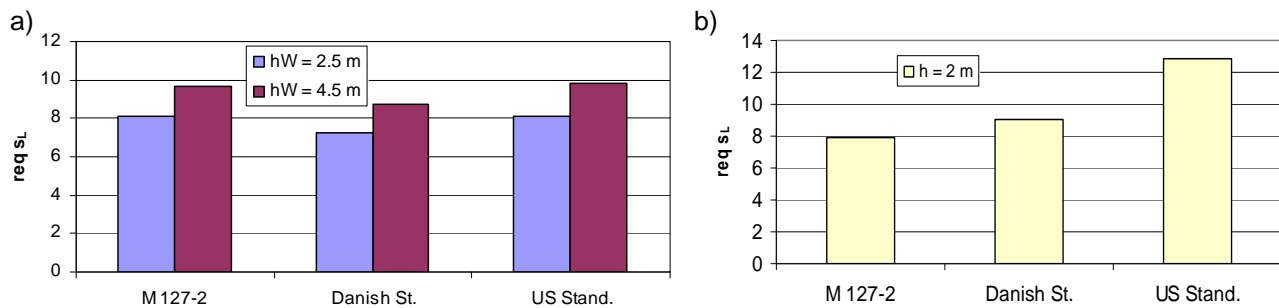

Figure 23a, b. Comparison of the required wall thickness of linings a) host pipe state I (water table h_w) and b) host pipe state III (soil cover h and traffic load)

Several experts have compared the necessary liner wall thickness for similar loading situations – a recent paper was presented at the NoDig Roma (Kuliczowski, 2007). From Figure 23a it is obvious that the differences in wall thickness for state I (and state II with cracks) are quite small. State III calculations show more significant differences, but the reasons could be discussed in the international expert community.

6. CONCLUSIONS

The German Design Code ATV-M 127-2:2000 has proved itself to be applicable for designing liners in very different rehabilitation projects. The stress analysis is the relevant proof for the structural safety of the construction allowing the design of lining material with low flexural strength as well. Stability analysis is easy to perform without the aid of a computer as a first step.

Open discussion in an international group of experts was helpful to identify common problems and to improve some clauses of the German Code ATV-M 127-2.

Future research needs are seen for host pipe state III situations (US definition: fully deteriorated), for railway crossings (e.g. fatigue tests) and for liner quality assurance.

6. REFERENCES

ATV-M 127-2:2000. Static calculations for the rehabilitation of sewers with lining and assembly procedures, Hennef (available in English language)

Danish standards (2001). Static calculations of liners for the gravitational sewers, Taastrup.

Falter, B. (1980). Grenzlasten von einseitig elastisch gebetteten kreiszylindrischen Konstruktionen. *Bauingenieur* 55, pp. 381-390. <http://hb051.fh-muenster.de/opus/fhms/volltexte/2005/165/>

Falter, B. (1991). Standsicherheitsnachweise an Sanierungssystemen für Abwasserkanäle mit unverankerten Linern. *3R International* 30, pp. 50-55. <http://hb051.fh-muenster.de/opus/fhms/volltexte/2005/142/>

Falter, B., Hoch, A. and Wagner, V. (2003). Hinweise und Kommentare zur Anwendung des Merkblattes ATV-M 127-2 für die statische Berechnung von Linern. *Korrespondenz Abwasser* 50, pp. 451-463. <http://hb051.fh-muenster.de/opus/fhms/volltexte/2003/95/>

Falter, B., Eilers, J., Müller-Rochholz, J. and Gutermann, M. (2008). Buckling Tests on PE-Linings with Egg Shape. *Geosynthetics International*. Vol 15 No 2 (April) 2008

Glock, D. (1977). Überkritisches Verhalten eines starr ummantelten Kreisrohres bei Wasserdruck von außen und Temperaturdehnung. *Stahlbau* 46, pp. 212-217.

Guice, L.K., Straughan, T., Norris, C.R. and Bennett, R.D. (1994). Long-Term Structural Behavior of Pipeline Rehabilitation Systems. TTC Technical Report #302, Louisiana Tech University Ruston, Louisiana, USA.

Kuliczowski, A., Kubicka, U. and Parka, A. (2007). The problems of design of resin liners. Proceedings of No Dig Conference Roma, September 10.-12. 2007.

Linerb 7.20 (2007). Structural analysis of linings – computer program. Interface in German and English language. Univ. of Appl. Sc. Münster. <https://www.fh-muenster.de/fb6/personen/lehrende/falter/linerb.php>

Timoshenko, S.P., Gere, J.M. (1961). Theory of Elastic Stability. *Mc Graw-Hill*, New York.

Watkins, R.K., Schupe, O.K. and Osborn, L.E. (1988). Contribution of Insituform to the structural integrity of broken rigid buried pipes. Insituform of North America, Inc.

WRc/WAA (2000). Sewerage rehabilitation manual. UK Water Research Center / Water Authorities Ass.